

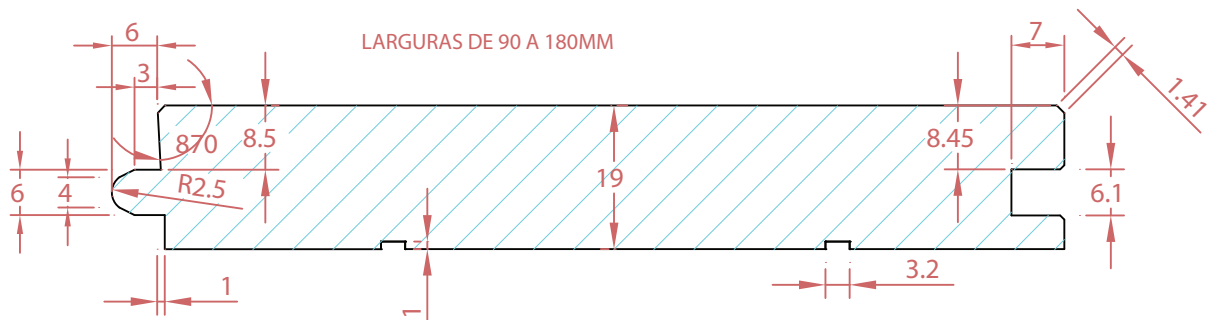

CASTRO & FILHOS, S.A.
INDÚSTRIA DE MADEIRAS

RÉGUA MACHEADADA 19mm VERNIZ

Corte transversal ao produto



Obs. o macho/femea dos topos é igual ao longitudinal

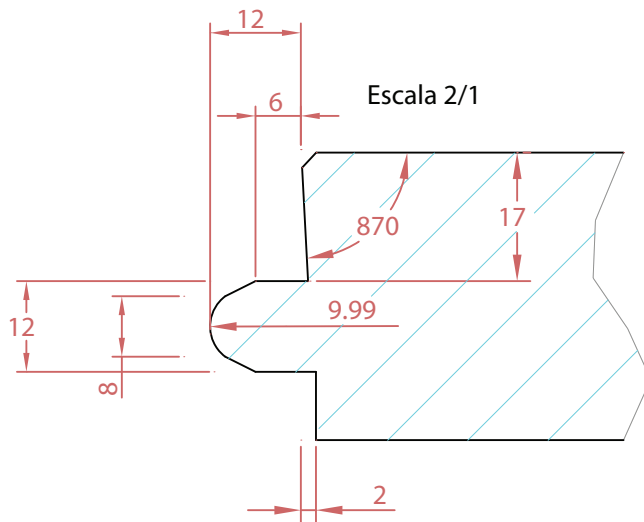

		Rua Padre João Moreira Leite, 1297 - 4800-611 Prazins Santa Eufémia Guimarães - PORTUGAL N.I.F.: PT 500059276 Tlf. 00 351 253 575 555/7 Fax. 00 351 253 575 550 E-mail: info@castrofilhos.pt	
		DES.	07/07/05
VER.	07/07/05		
ESC.	1:1	Régua de 19mm para envernizar	
TOL.		DES. N C&F N° 11	
		SUBS. O	
		SUBS. POR	